

LNF - 66/1  
21 Gennaio 1966

I. Modena, V. Montelatici and F. Scaramuzzi: A LIQUID He<sup>3</sup>  
TARGET FOR HIGH ENERGY NUCLEAR EXPERIMENTS. -

(Nota interna: n. 302)

LNF-66/1

Nota Interna: n° 302  
21 Gennaio 1966

I. Modena, V. Montelatici and F. Scaramuzzi: A LIQUID He<sup>3</sup> TARGET FOR HIGH ENERGY NUCLEAR EXPERIMENTS. -

#### INTRODUCTION. -

A liquid He<sup>3</sup> target has been constructed for experiments on He<sup>3</sup> photodisintegration using the  $\gamma$ -beam of the Frascati 1.1 BeV electron synchrotron.

The cryostat is a development of a standard hydrogen/deuterium (HD) target in use with the Frascati electron synchrotron<sup>(1,2)</sup>. For a detailed description of the HD target we refer the reader to the bibliography. However a brief summary of its characteristics could be helpful. A reservoir of  $\sim 6$  lt of liquid hydrogen is connected with a cell, which acts as the target. A radiation shield cooled by liquid nitrogen surrounds the liquid hydrogen reservoir and the cell, except for two holes cut for the beam inlet and outlet: this reduces the heat input to the hydrogen reservoir and to the cell. The liquid nitrogen reservoir has a capacity of  $\sim 30$  lt. The whole system is contained in a vacuum tank and in the upper portion of the cryostat (above the target) multiple layer shielding is provided to lower the heat input to the liquid nitrogen reservoir. To fill the target with liquid deuterium, the cell is isolated from the reservoir, deuterium gas from a constant volume tank is condensed in a coil immersed in the liquid hydrogen reservoir and fills the target. This sophisticated solution was chosen for the cryostat mainly to reduce both the quantity of liquid hydrogen present in the experimental hall and the frequency of fillings. In fact, the running time of the HD cryostat was very satisfactory, reaching two weeks. Another advantageous feature of this solution is the fact that different cells, with

2.

different geometries, can be mounted on the same cryostat. This is the main reason why we developed this kind of cryostat in place of the old Littauer-Wilson type<sup>(3, 4)</sup>. Facilities are provided in such cryostats to empty and fill the cell, while liquid hydrogen is in the reservoir. Liquid He<sup>4</sup> can be put into these cryostats in place of hydrogen in order to have a liquid He<sup>4</sup> target, but the evaporation rate is pretty high,  $\approx 0.2$  lt/h, corresponding to a running time of about 1 day.

The main modifications of the HD cryostat which led to the cryostat described in this note are as follows (note that they all have the object of giving a long running time):

To reduce the heat input all the piping necessary to permit the emptying and filling of the cell have been eliminated, leaving only the liquid level controls.

He<sup>3</sup> is condensed in a coil passing through a bath of liquid He<sup>4</sup> under reduced vapor pressure ( $\approx 78$  mm Hg = 2.5°K).

In order to be sure that the target is full of liquid, the gas is supplied until the pressure above the liquid He<sup>3</sup> is slightly higher than the vapour pressure at that temperature ( $\approx 380$  mm Hg).

To cut the heat input to both He<sup>4</sup> and He<sup>3</sup> containers a liquid hydrogen shield and an outer liquid nitrogen shield have been realized.

## DESCRIPTION OF THE CRYOSTAT. -

Fig. 1 shows a schematic drawing of the cryostat. The vacuum tank contains the three coaxial containers which are thermally insulated from each other by the vacuum and by thin-walled stainless steel tubing. a is the liquid nitrogen container, b is the liquid hydrogen container, c is the liquid He<sup>4</sup> container, d is the target containing liquid He<sup>3</sup>, e is an extension of the main liquid nitrogen container, connected with the latter through the coil f, which at the same time cools the shield g. This shield is fastened to the tank e simply by means of screws. Another inner and colder shield h is fastened in the same way to the hydrogen container b. The He<sup>3</sup> condenser i consists of a copper tube (3 mm o.d. ; 1 mm i.d. ) wound in a helix, joined to a straight upper section made of stainless steel tubing (2 mm o.d. ; 1.6 mm i.d. ). j is a pack of multiple layer shielding which reduces the heat inlet to the nitrogen reservoir. In the two cooled shields g and h holes are cut in the directions of the incoming  $\gamma$ -beam and of the emerging particles, in order to reduce the background radiation in the experiment. In the directions of the holes, the only protection against thermal radiation at room temperature is a single sheet of thin aluminium foil (thickness 0.01 mm). The outer tank is made of three different pieces connected to each other with O-ring systems. The lower part has a large window on which a film of 0.175 mm

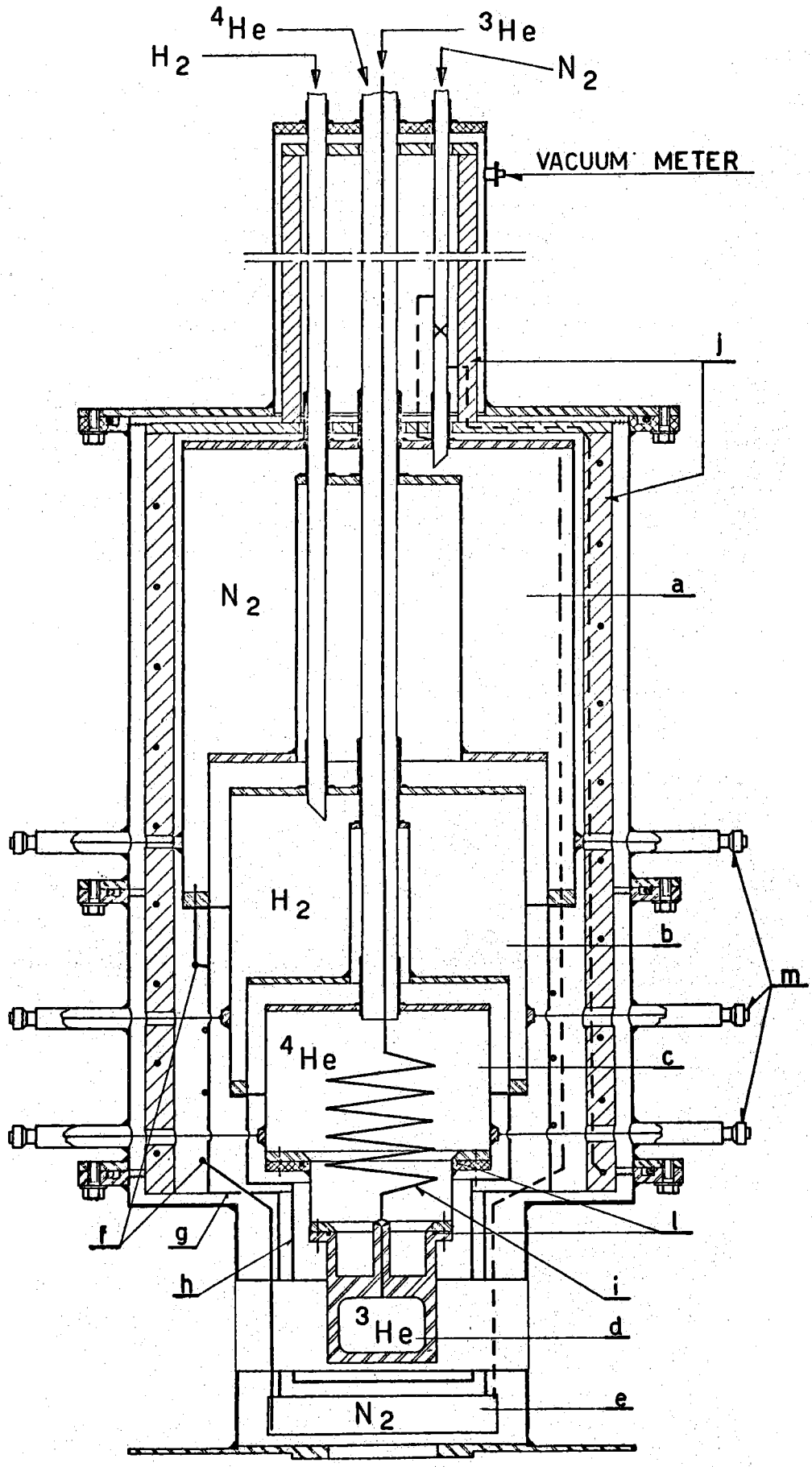

FIG. 1 - Schematic drawing of the cryostat. The symbols are explained in the text.

4.

thick mylar is glued with araldite. The  $\text{He}^4$  and  $\text{He}^3$  tanks are made of three pieces fastened with indium seals 1. The pumping system for the insulating vacuum is connected at the bottom of the cryostat. The three sets of spacers, m, made of nylon thread, with four spacers in each set, have a double function; firstly to prevent any contact between parts due to deformation during the thermal cycles, and secondly to give the position of the centre of the target with a precision of  $\sim 1$  mm. The upper set determines the position of the liquid  $\text{N}_2$  tank with respect to the outer tank, the middle set does the same for the liquid  $\text{H}_2$  container, the lowest for the liquid  $\text{He}^4$  container.

#### THE CELL. -

The cell has the shape of a cuboid 4 mm thick, 8 cm wide, 4 cm high (see fig. 2). The thin nickel walls a (0.03 mm thick) were welded with cusil (trade mark WESGO, USA) alloy in a hydrogen atmosphere to a nickel block b.

In order to ensure the best possible thermal contact between the liquid  $\text{He}^3$  in the cell and the liquid  $\text{He}^4$  bath, the block was made in one piece, and contains liquid  $\text{He}^4$  in the upper section.

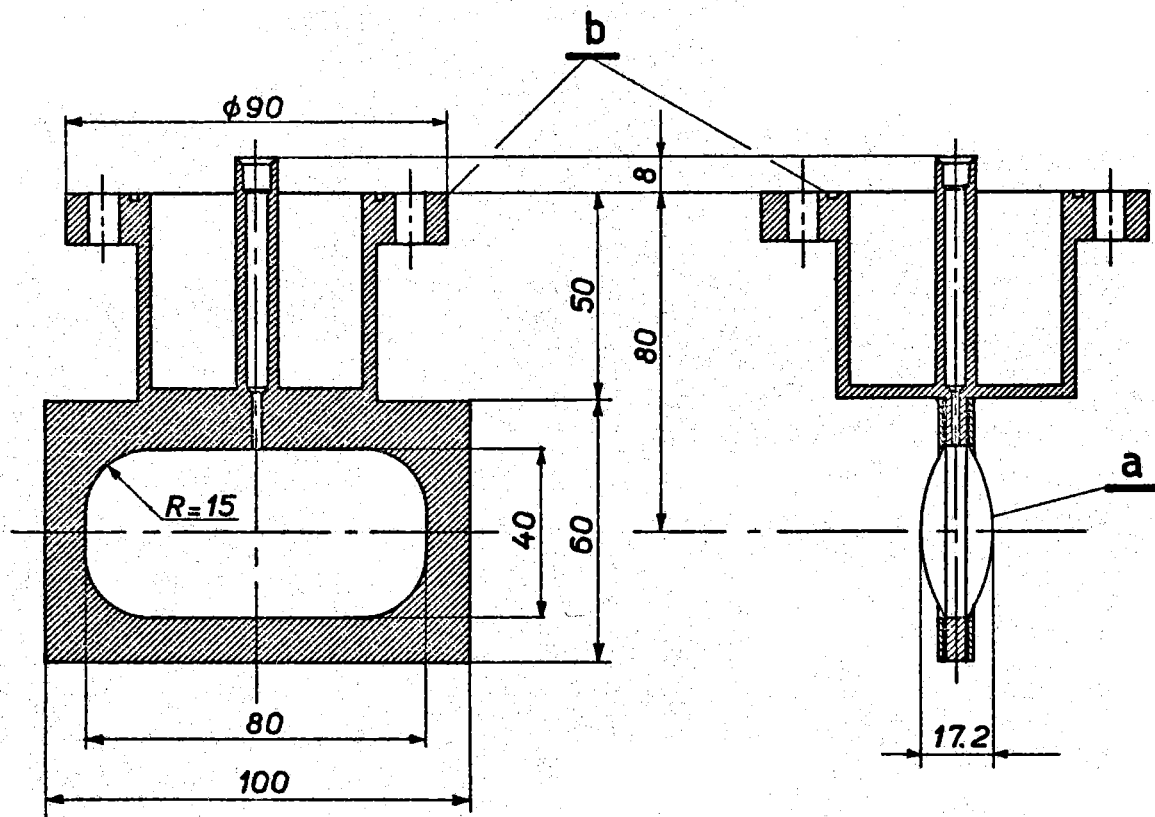

FIG. 2 - Two perpendicular vertical sections of the cell (target). The dimensions are given in mm.

Due to the pressure difference between the  $\text{He}^3$  container and the vacuum space outside, the thin nickel walls assume a round shape which has a maximum thickness of 17.2 mm in the center. A map of the thickness has been made for the users of the target.

We have attempted to use a range of materials, and various types of welding. At present we have begun the construction of a cell made with stainless steel films welded in a vacuum oven to nickel body.

#### THE FLOW DIAGRAM. -

Figure 3 shows a schematic diagram of the flow circuit.

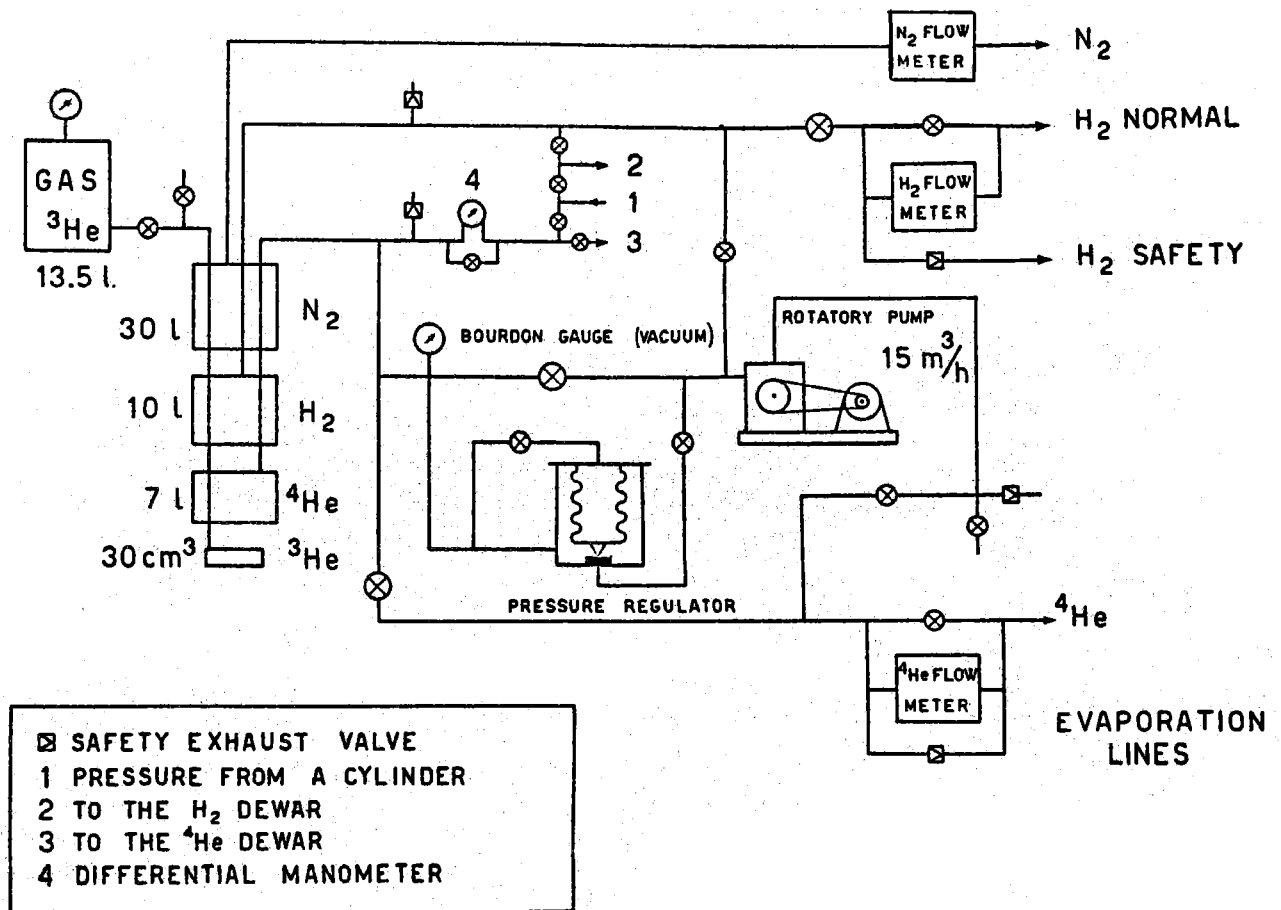

FIG. 3 - Schematic diagram of the flow circuit. The pressure lines 1, 2 and 3 and the differential manometer 4 are used to supply pressure for the  $\text{H}_2$  and  $^4\text{He}$  transfer.

6.

The He<sup>3</sup> line is extremely simple. It consists of a tank of volume 13 lt, which is initially filled with  $\sim 24$  lt NTP of He<sup>3</sup>, at a pressure of  $\sim 1.9$  atm (absolute). One stopcock separates this tank from the condenser line. When the target is cooled to  $\sim 2.5^\circ\text{K}$ , the stopcock is opened and the He<sup>3</sup> condenses in the target. The quantity of He<sup>3</sup> is such that all the cell and part of the condenser are filled with the liquid and the rest of the gas remains in the tank at about the vapour pressure above the liquid.

The He<sup>4</sup> circuit contains a normal evaporation line and a line served by a vacuum rotatory pump. A manostat type pressure regulator (Croft and White<sup>(5)</sup>), keeps the He<sup>4</sup> vapour pressure at the desired value, and thus the temperature constant.

Normal evaporation lines are provided both for the hydrogen and for the nitrogen.

For all three lines (He<sup>4</sup>, H<sub>2</sub> and N<sub>2</sub>) gas flow counters are provided to control the behaviour of the cryostat and to know at any time the various volumes of liquids in the cryostat (This, by the way, can also be done for the He<sup>4</sup> and H<sub>2</sub> by direct measurement of the liquid level).

#### TESTS AND PERFORMANCE. -

Vacuum tests have been made, step by step, on the cryostat, as for all the HD cryostats. For the cold parts, the tests have been made at liquid nitrogen temperatures as well.

Special care has been dedicated to the safety tests for the thin walled nickel cell. A few dummy cells have been made and broken. The cell to be used was tested at a pressure double the working pressure and an accurate search for vacuum leaks was then made both at room temperature and liquid nitrogen temperature.

Before bringing the cryostat into the synchrotron experimental hall, it was fully tested in our laboratory. The results of these tests are summarized in the table I.

TABLE I

Liquid	Capacity of reservoir (in lt)	Evaporation rate at equilibrium (in lt/h)	Running time (in hours)	Filling time (in hours)
N <sub>2</sub>	30	0,17	170	~ 0,8
H <sub>2</sub>	10	0,05 (0,006) <sup>(x)</sup>	160	~ 1
He <sup>4</sup> (at 4.2°K)	7	---	---	~ 1
He <sup>4</sup> (at 2.5°K)	~ 4	0,04	~100	---

## REFERENCES. -

- (1) - V. Montelatici, LNF 62/20 (1962).
- (2) - V. Montelatici, Nuclear Inst. and Methods, 29, 121 (1964)
- (3) - Littauer, Rev. Sci. Instr. 29, 178 (1958).
- (4) - R. Wilson, Rev. Sci. Instr. 29, 273 (1958)
- (5) - G. K. White, Experimental techniques in low temperature physics, (Clarendon Press, Oxford, 1959) pag. 206.

---

(x) - Evaporation in presence of He<sup>4</sup>. -